

WATER DEMAND MANAGEMENT IN THE EXPANDING URBAN AREAS OF SOUTH ATTICA

ROZOS E.¹, PHOTIS Y.² and MAKROPOULOS C.¹

¹ School of Civil Engineering, National Technical University of Athens, Heroon Polytechneiou 5, Athens, GR-157 80, ² School of Rural and Surveying Engineering, National Technical University of Athens, Heroon Polytechneiou 5, Athens, GR-157 80
E-mail: rozos@itia.ntua.gr

ABSTRACT

Modern decentralized water-aware technologies (including for example grey water recycling and rainwater harvesting) enable water reuse at the scale of household or neighbourhood. Such options reduce the pressure on the infrastructure and alleviate the need for upgrading the centralized infrastructure, hence reducing the cost of urban growth. To study the benefits of the water-aware technologies on expanding urban areas, an urban water cycle and a land use model were coupled. The former, UWOT, is a bottom-up urban water model that simulates the generation, aggregation and routing of demand signals (potable water demand, runoff discharge demand, and wastewater discharge demand). The latter, SLEUTH, is a cellular automaton model of urban land use change (see project GIGALOPOLIS). The coupling of UWOT and SLEUTH was tested in South Attica. Cellular automaton models use a group of discrete units to simulate the land use evolution of the studied area. For this reason, classes of land uses should be formed based on a set of predefined criteria. The criteria of the classification of the South Attica were the population per cell, the total built area per cell and the population per building. SLEUTH was calibrated using the 2001-2011 census data. Then, SLEUTH was used to simulate the urban expansion and intensification. The simulation period spanned from 2011 to 2031. Afterwards, the results of SLEUTH were fed into UWOT, which simulated the conventional network of this area to estimate the evolution of the water demand, the runoff and the wastewater generation. Finally, a sequence of simulations were performed assuming that the network of all new buildings (those built between 2011 and 2031) incorporated water-saving schemes and that water-saving schemes were being installed in the existing buildings (those built before 2011) with a constant penetration rate. The only difference among the simulations of this sequence was the time of the initiation of the water-saving schemes installation. This provided a nomograph with a group of lines corresponding to potable water demand for different intervention timings and various penetration rates. This nomograph could be used in supporting either the planning of the expansion of the water services to newly urbanized areas and/or the decisions regarding the maintenance and capacity increase of the existing infrastructure.

Keywords: urban water cycle model, land use model, water demand management

1. Introduction

Traditionally, urban water infrastructures provide drinking water for all uses and drain all rainwater and sewage. However, the modern decentralized recycling technologies (including, for example, low water consumption and rainwater harvesting) allow reusing the water in household or neighbourhood scale. These options can reduce the pressure on networks and alleviate the need for upgrading the central infrastructure, which, consequently, reduces the cost of urban development. To study the benefits of decentralised recycling technologies in expanding urban areas, an urban water cycle model, UWOT, was combined with a land use model.

UWOT is a bottom up (micro-component based) urban water cycle model that simulates the demand starting at the water appliance level. Urban water models often use a hydraulics-based

conceptualisation of the urban water network, simulating actual water flows, including runoff, potable water and wastewater. UWOT uses an alternative approach based on the generation, aggregation and transmission of a demand signal, starting from the household water appliances and moving upstream and downstream. The simulation provides timeseries of: i) potable water demand, ii) water level fluctuation inside tanks and reservoirs, iii) leakages, iv) evaporation, v) runoff, vi) energy consumption (including both energy required for water circulation, e.g. pump of rain-water inside tank, and energy consumed by the water appliances, e.g. heat water for showering), vii) capital and operational costs. An analytical description of UWOT is provided by Rozos and Makropoulos (2013) and Rozos *et al.* (2013).

Land use change is driven by interactions in time and space between people and the environment. In recent decades, land-use change models have helped in understanding the causes and mechanisms and consequences of the dynamics governing land use. The success of these models has been favoured by the availability of satellite images of high-resolution and precision, as well as by the wide accessibility to increased computing power. Among the model types that are used for the study of land use change, Cellular Automaton (CA) is the most popular, primarily because of the simplicity. These models divide (discretize) study area on cells with the behaviour of each cell determined by rules of transition, which in essence represent the uncertainties and the driving forces of the real world related to urbanization. SLEUTH is a CA model that combines terrain mapping and deltatronic land use modelling to simulate urban development (Project Gigalopolis, 2015).

2. Sleuth and uwot setup

The demographic data required for the classification of the studied area was obtained from ESYE (2015).

Table 1: Criteria used to classify urban cells of studied area.

	Type 1	Type 2	Type 3	Type 4
POP_AREA	1000	5500	7000	14000
IMP_AREA	8	24	11	32
POP_BUILD	1	3	12	6

Where POP_AREA is the inhabitants per square kilometre, IMP_AREA is the percentage of built area and POP_BUILD is the average building occupancy.

Afterwards, four land use types were defined (see Table 1). For the representation of the classification of the studied area, a raster map with resolution 118x118 m² was prepared. The cells of this raster map were assigned an id corresponding to the closest land use type. The raster map with the classification of the 2011 urban cells is shown in the following figure. This map is actually the initial conditions of the SLEUTH model.

Each one of the four urban types was simulated with UWOT. Initially, a Business As Usual (BUA) approach was assumed. This approach includes a conventional household network. Afterwards, a Rain Water Harvesting (RWH) scheme (see Figure 2) was investigated and finally the use of low consumption appliances (LOW) was assessed.

These three configurations (BUA, RWH and LOW) invite equivalent number of independent UWOT simulations. One set of three UWOT simulations was performed for each one of the four urban types, resulting in twelve simulations in total. The simulations were performed using daily time step (historical daily rainfall timeseries was obtained from FreeMeteo) with the simulation period extending from 1 January 1980 to 31 December 1999. The final step of UWOT and SLEUTH coupling includes the Cartesian product of SLEUTH results with the results of UWOT.

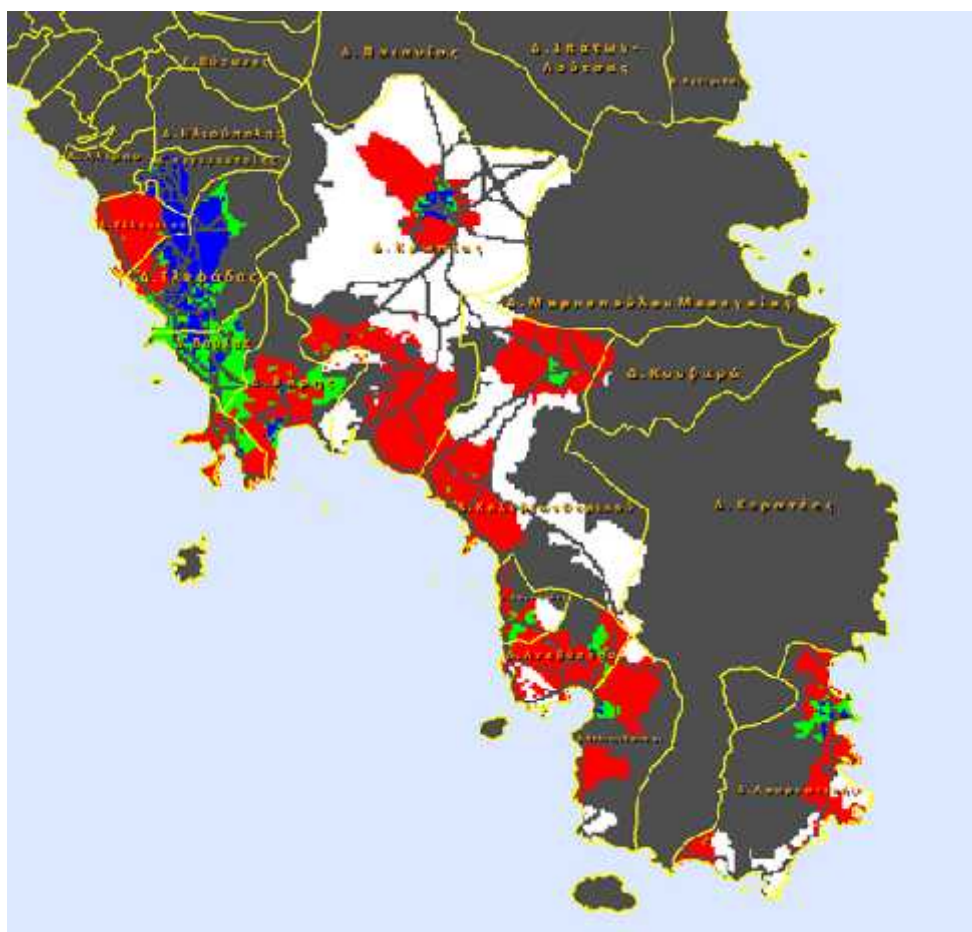

Figure 1: Spatial distribution of 2011 urban cells. White, red, green, blue for types 1 to 4 respectively.

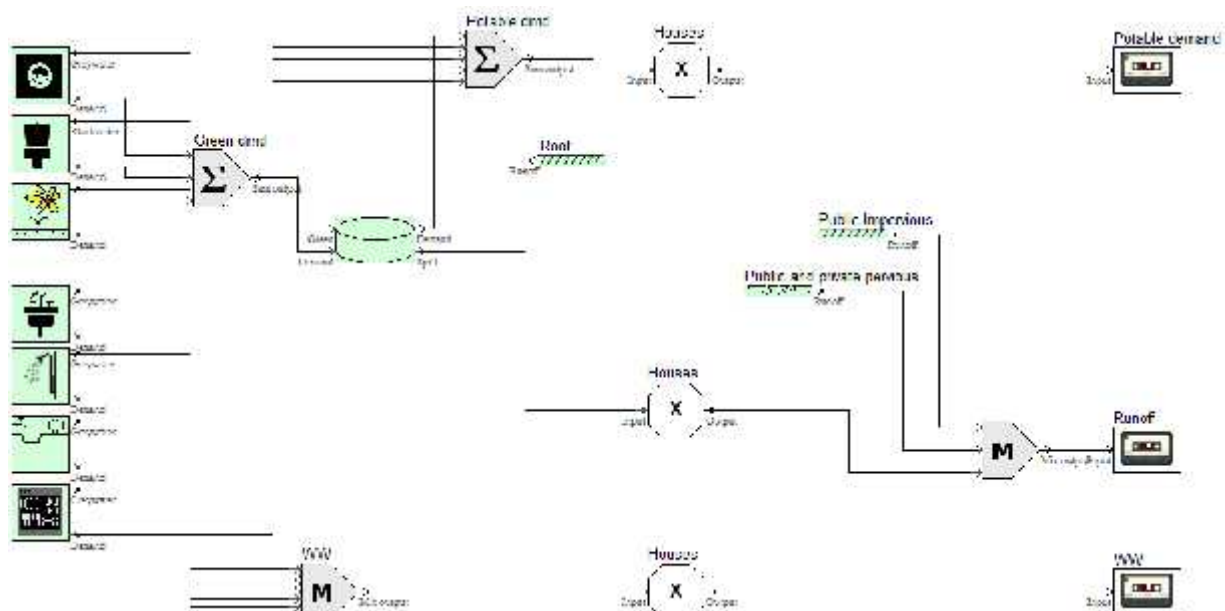

Figure 2: Representation of a household network in UWOT.

3. Results

The results of the SLEUTH model in the studied area are shown in the following figure.

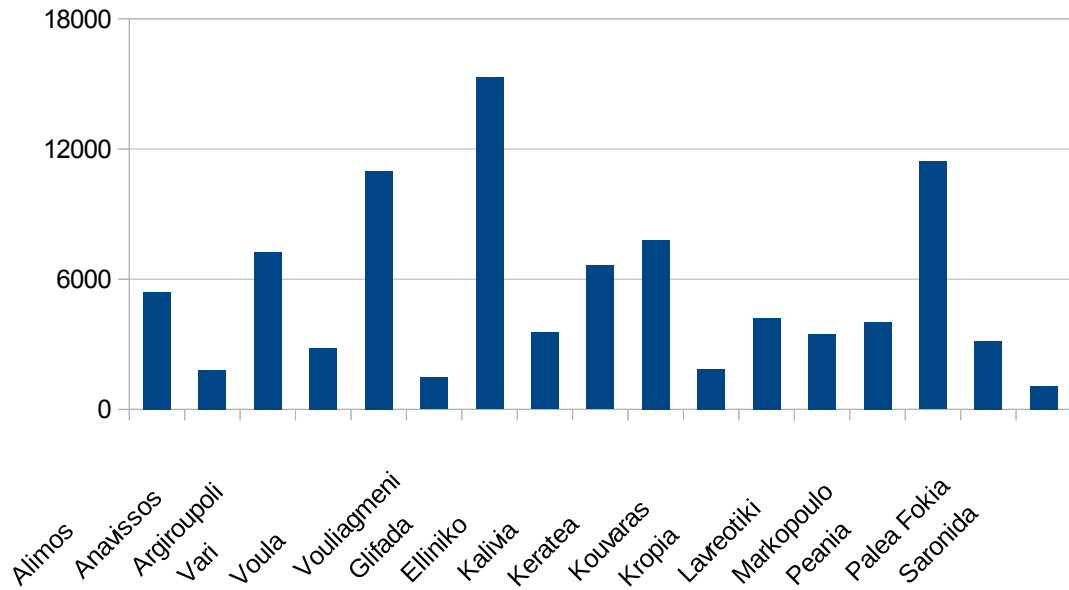

Figure 2: Estimated population change per municipality between 2011 and 2031.

The combination of UWOT results and the 2031 results of SLEUTH provides an estimation of potable water demand for the three configurations (Figure 3).

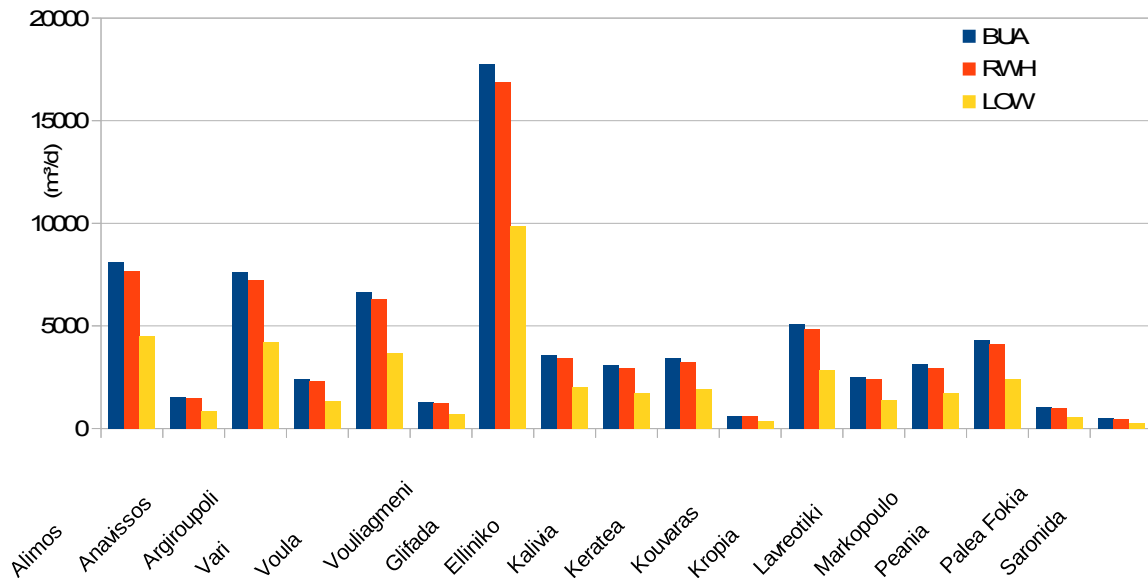

Figure 3: Estimated average daily potable water demand per municipality in 2031.

Finally, in order to facilitate the planning of interventions, UWOT was applied on the intermediate SLEUTH results (results corresponding to years between 2011 and 2031) for various penetration rates and assuming different uptake year (initiation of installation of low water consumption appliances). This resulted in a set of estimated potable water demand values, which is displayed in the following figure.

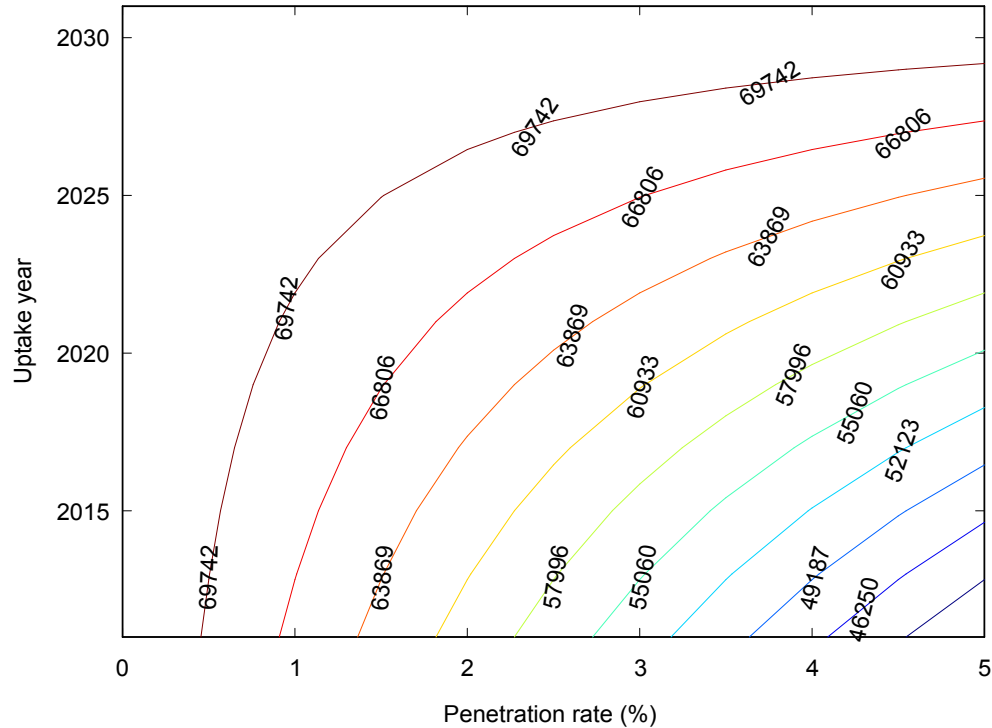

Figure 4: Estimated daily potable demand of the studied area (m³/d) in 2031 for different uptake years and penetrations rates.

5. Conclusions

In this study an urban water cycle model (UWOT) was coupled with a land use model (SLEUTH) to estimate the impact of urban expansion in an area in North Attica, Greece. The coupling of these models allowed preparing a nomograph that could facilitate the decision making concerning the optimum intervention timings taking into account realistic values of the new technologies' penetration rate.

ACKNOWLEDGMENT

This research has been co-financed by the European Union (European Social Fund– ESF) and Greek national funds through the Operational Program "Education and Lifelong Learning" of the National Strategic Reference Framework (NSRF) - Research Funding Program: THALES. Investing in knowledge society through the European Social Fund.

REFERENCES

1. ESYE (2015) URL: <http://www.statistics.gr/portal/page/portal/ESYE/PAGE-database> (accessed 12/01/2015).
2. Rozos, E., and Makropoulos, C. (2013). Source To Tap Urban Water Cycle Modelling. Journal of Environmental Modelling and Software, DOI:10.1016/j.envsoft.2012.11.015.
3. Rozos, E., Makropoulos C., and Maksimovic C. (2013) Rethinking urban areas: an example of an integrated blue-green approach, Water Science and Technology: Water Supply, 13 (6), 1534-1542, doi:10.2166/ws.2013.140.
4. Project Gigalopolis (2015) URL: <http://www.ncgia.ucsb.edu/projects/gig/> (accessed 12/01/2015).